

ELECTRIC

THE ALL-NEW
T880E1



T880E1



The Industry's First Electric Class 8 Work Truck

- Available in 6x4 Truck or Tractor
- Set-Back or Set-Forward Front Axle Configuration
- Up to 82,000 GCWR
- Up to a 625 kWh Battery with 250+ Miles of Range
- Midship eMotor, Providing Flexible Frame Lengths and Content
- Industry-Leading 350 kW Charge Rate
- Available with DigitalVision Mirrors, Enhancing Jobsite Visibility



DriverConnect Display

- 15" Touchscreen B-Panel Display
- BEV-Specific App Integration
- Ergonomic Design for Ease of Use



Work-Truck Focused

- Customizable Wheelbase & Lift Axles
- Seamless Body Integration
- Heavy Rear Suspension & Axles Available



ePTO Integration

- Factory Routings & Harnessing Available
- Factory Dash Switches Available
- Multiple ePTO Power Options

T880E BATTERY ELECTRIC VEHICLE CHASSIS OVERVIEW

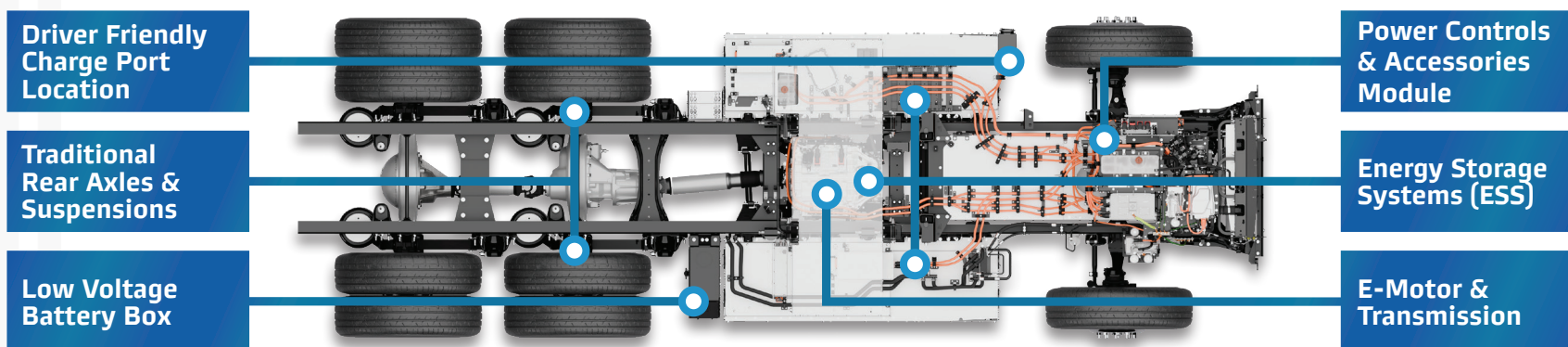

- Fully Integrated PACCAR ePowertrain
- Lithium Iron Phosphate Battery Chemistry
- 3-Speed Integrated Transmission
- Ratings up to 450 kW/605 hp peak, 1,850 lb-ft

BATTERY STRING CONFIGURATIONS

2 String

250 kWh
100 mi

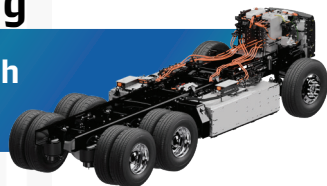

3 String

375 kWh
150 mi

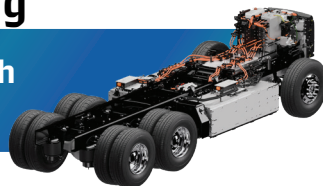

4 String

500 kWh
200 mi



5 String

625 kWh
250 mi



T880E1

SPECIFICATIONS



PACCAR EPOWERTRAIN

Configuration	6x4
GCW	Class 8: Up to 82,000 lbs. <i>Configuration Specific</i>
Transmission	Integrated 3-Speed
eMotor Weight	847 lbs.
System Voltage	650V
Current AC	520 A (Peak) / 350 A (Cont.)
Wheelbase	Minimum 190"

Continuous Power	Peak Power	Peak Torque	Battery Strings
365 hp (270 kW)	470 hp (350 kW)	1,850 lb-ft	2 to 5
415 hp (310 kW)	540 hp (400 kW)	1,850 lb-ft	3 to 5
470 hp (350 kW)	605 hp (450 kW)	1,850 lb-ft	3 to 5

Battery:

String Configuration	Capacity (kWh)	Range Estimated (mi)
2	250	100
3	375	150
4	500	200
5	625	250

Charging

DC Fast Charger,
350 kW Standard

Optional 19 kW
AC Charger

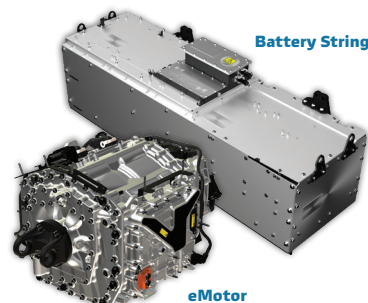

ePTO:

25 kW Low-Power Socket

150 kW High-Power Socket

Factory-Installed Dash Switches

Warranty & Serviceability:

Component	Warranty	Months	Mileage/Hours
HD Electrical Drive System	Standard	36	300,000 mi ¹
	Extended	150	500,000 mi ¹
Battery ²	Standard	200	500,000 mi

Disclaimer: Actual range depends on many factors including geography, climate, operator and duty cycle.

² 4,000 Cycles & 70% SoH

¹ eMotor, eAccessories, eControls, ePowertrain Related Components



A PACCAR COMPANY

KENWORTH TRUCK COMPANY
P.O. BOX 1000
Kirkland, Washington 98083-1000
(425) 828-5000

CANADIAN KENWORTH COMPANY
6711 Mississauga Road N.
Mississauga, Ontario L5N 4J8
(905) 858-7000



Note: Equipment and specifications in this brochure are subject to change without notice. Images of equipment/components shown in this brochure are not to scale. Consult with your Kenworth dealer at time of ordering for standard and optional equipment and are subject to supply/availability.

T880E/25 © 2025 Kenworth Truck Co.



DRIVING TO
ZERO
EMISSIONS™