

ELECTRIC

THE NEXT GENERATION  
**T680E1**



# T680E1



## Next-Generation Zero-Emissions Platform

- Available in 6x4 Truck or Tractor
- 56,000 GVWR & 82,000 GCWR
- Less than 2 Hours of Charge Time at 350 kW
- eMotor Power Ratings up to 450 kW / 605 hp Peak
- Up to a 500 kWh Battery with 200+ Miles of Range
- Available DigitalVision Mirrors, Enhancing Aero Efficiency



## DriverConnect Display

- 15" Touchscreen B-Panel Display
- BEV-Specific App Integration
- Ergonomic Design for Ease of Use



## Technology-Forward Cab

- Available Kenworth ADAS Suite of Features
- BEV-Specific Displays, Data & User Interface
- All-New Redesigned Kenworth Interior



## Aero Leadership

- Maximized Range & Efficiency with Aero Features
- Fairings, Turning Vanes, Side Extenders (Standard)
- Leverages T680 Aerodynamic Short Hood

## T680E BATTERY ELECTRIC VEHICLE CHASSIS OVERVIEW

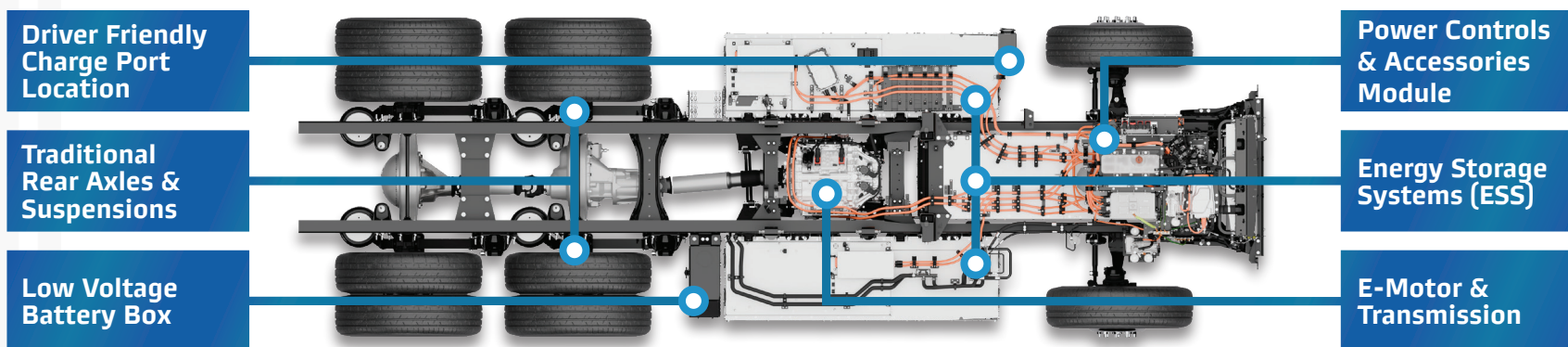

- Fully Integrated PACCAR ePowertrain
- Lithium Iron Phosphate Battery Chemistry
- 3-Speed Integrated Transmission
- Ratings up to 450 kW/605 hp peak, 1,850 lb-ft

## BATTERY STRING CONFIGURATIONS

### 2 String

250 kWh  
100 mi



### 3 String

375 kWh  
150 mi

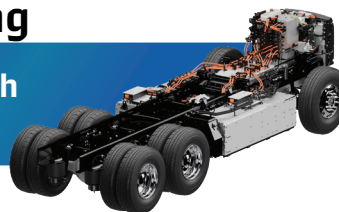

### 4 String

500 kWh  
200 mi



# T680E1

## SPECIFICATIONS



### PACCAR ePOWERTRAIN

Configuration	6x4	Continuous Power	Peak Power	Peak Torque	Battery Strings
GCW	Class 8: Up to 82,000 lbs. <i>Configuration Specific</i>	365 hp (270 kW)	470 hp (350 kW)	1,850 lb-ft	2 to 4
Transmission	Integrated 3-Speed	415 hp (310 kW)	540 hp (400 kW)	1,850 lb-ft	3 to 4
eMotor Weight	847 lbs.	470 hp (350 kW)	605 hp (450 kW)	1,850 lb-ft	3 to 4
System Voltage	650V				
Current AC	520 A (Peak) / 350 A (Cont.)				
Wheelbase	Minimum 190"				

### Battery:

String Configuration	Capacity (kWh)	Range Estimated (mi)
2	250	100
3	375	150
4	500	200

### ePTO:

25 kW Low-Power Socket
150 kW High-Power Socket
Factory-Installed Dash Switches

**Disclaimer:** Actual range depends on many factors including geography, climate, operator and duty cycle.

### Charging

DC Fast Charger,  
350 kW Standard

Optional 19 kW  
AC Charger

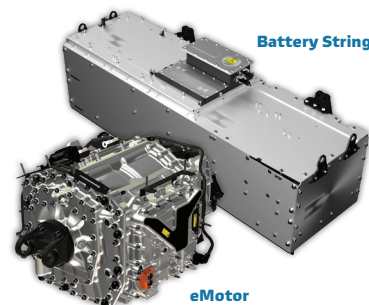

### Warranty & Serviceability:

Component	Warranty	Months	Mileage/Hours
HD Electrical Drive System	Standard	36	300,000 mi <sup>1</sup>
	Extended	150	500,000 mi <sup>1</sup>
Battery*	Standard	200	500,000 mi

\* 4,000 Cycles & 70% SoH

<sup>1</sup> eMotor, eAccessories, eControls, ePowertrain Related Components



A PACCAR COMPANY

KENWORTH TRUCK COMPANY  
P.O. BOX 1000  
Kirkland, Washington 98083-1000  
(425) 828-5000

CANADIAN KENWORTH COMPANY  
6711 Mississauga Road N.  
Mississauga, Ontario L5N 4JB  
(905) 858-7000



Note: Equipment and specifications in this brochure are subject to change without notice. Images of equipment/components shown in this brochure are not to scale. Consult with your Kenworth dealer at time of ordering for standard and optional equipment and are subject to supply/availability.

T680E/25 © 2025 Kenworth Truck Co.



DRIVING TO  
ZERO  
EMISSIONS™